

Assembly instruction for Pfitfit point of purchase

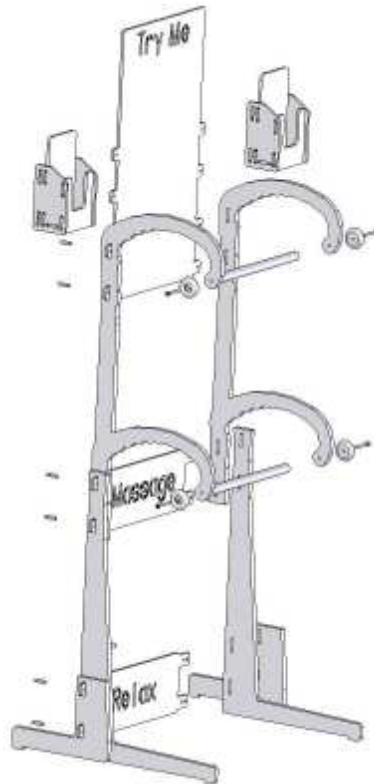

Explode view



1. Assemble left side to back pieces & tap pegs into holes with hammer to connect back pieces to side pieces.



2. Assemble right side & tap pegs into other side back pieces.

Notes:

Assembly Tools Needed :

-Need hammer

-Screw driver

Disassembly tools

-Pliers or hammer and 3/16 punch

-Use 3/16 punch and tap peg out.

-To disassemble with pliers grip wood peg and pull out. There is a good chance you may damage peg so we include extra pegs just incase you have to take a peg out.

-If you have pegs that are loose, try a different peg because the diameter are a little different.

Parts list

-1 Relax back

-1 Message back

-1 Try me back

-2 Small bottom brackets

-2 Large bottom brackets

-2 Double hook pieces

-2 3/4 Dowels

-4 Wheels

-20 1/4 Dowels

-4 Wood screws

-2 Brochure holder & Brochures

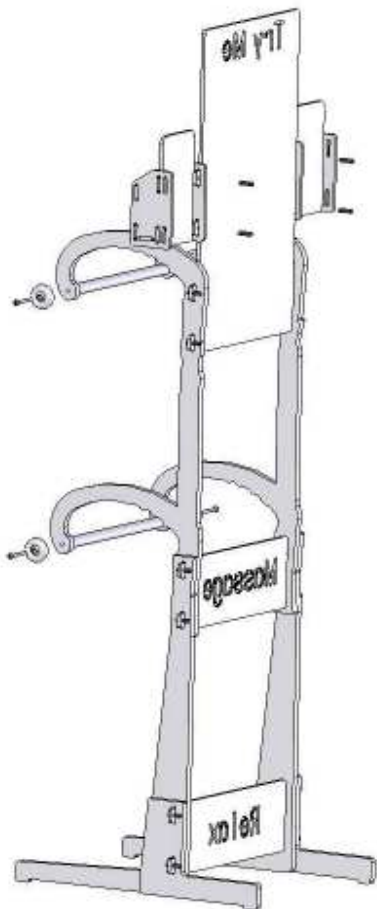

3. Attach brochures box to top back piece and tap in pegs with hammer.



4. Use a phillips screw driver to attach dowels and wheels with supplied wood screws.